

TASMANIAN HARDWOOD OVERLAY FLOORING

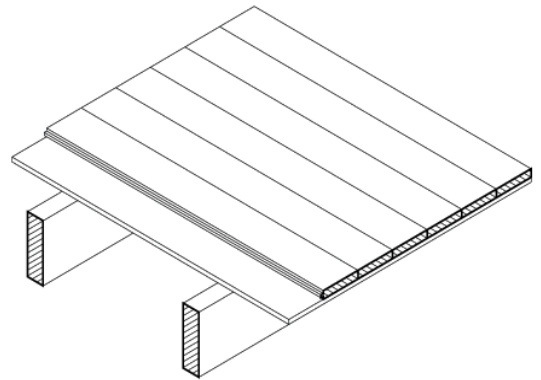

installation guide

These instructions apply to quality Tasmanian strip flooring used as an overlay on a structural substrate in residential applications.



nail glue

SHEET FLOORING OR BOARDS

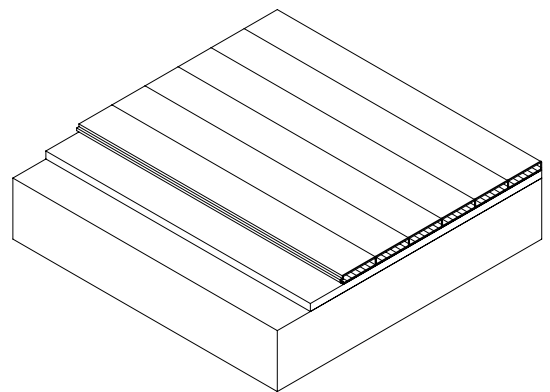

nail glue

PLYWOOD ON CONCRETE

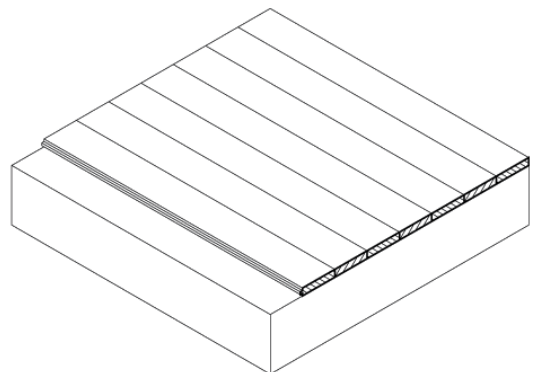

glue

CONCRETE

TOOLS

Simple tools are adequate in most applications.

Necessary tools are:

✓ Tool Requirement Checklist		✓	
	Pencil, tape measure and square		Hammer and nail bag
	Stringline, spirit level and straight edge		Hand saw and jig saw
	Safety glasses, dust mask and knee pads		Spacers (about 100mm long and 2 mm thick)
	Glue spreader		Broom and vacuum cleaner

For specialist applications, a drop saw, an air powered staple gun, a power actuated fastener system and a cramping system may be useful.

MATERIALS

Use quality boards of the correct thickness.

Product and grade descriptions for strip flooring are set out in the Australian Standard AS 2796 and are available at: www.tastimber.tas.gov.au.

12 - 13 mm thick tongue and groove boards must be continuously supported on a structural substrate, such as plywood or concrete, or on closely spaced battens. If boards are fixed directly to joists, they need to be at least 19 mm thick to span 450mm.

Board width for nail only application - *Only secret nail boards up to 85 mm cover width.*

Secret nailed flooring is fixed through the tongue of specially profiled boards. Since they are only secured with one fastener per joist or position, their width in nail only applications is limited to 85 mm cover.

Use only specialist elastomeric glues. Do not use hard setting glues.

Flooring glues need to allow for movement in the timber. Companies that make them include Bostik, Toby, Fullers & Ramset. Follow the manufacturer's recommendations exactly.

Use compatible levelling, sealing and gluing products.

Manufacturers develop products to work as a system. Mixing brands of products can cause incompatibility problems and void guarantees. Follow the manufacturer's recommendations exactly.

Use the correct nails for the job.

Use 30mm concrete nails with washers for fixing overlay to concrete.

If the boards are not being glued, the nail sizes required by Australian Standard 1684 are:

T & G flooring to plywood substrate*	
Flooring thickness	Rec. nailing (min. 15mm subfloor)
19 or 20	38 x 16 gauge staples or 38 x 2.2mm nails at 300mm spacing
12,19 or 20	32 x 16 point staples or 30 x 2.2mm nails at 200mm spacing

*Alternative fasteners can be used for substrates types not listed subject to manufacturers' recommendation.

MOISTURE CONTENT OF THE TIMBER

Timber is a natural product. Its dimensions vary with changes in surrounding moisture.

As timber absorbs moisture to remain in equilibrium with its surrounding atmosphere, it expands. As it loses moisture, it shrinks. Strip flooring will always move slightly between boards as the ambient conditions of the surrounding environment change. So, to produce a successful timber floor, the timber needs to be installed at the correct moisture content, changes in the ambient conditions controlled and any movement accommodated.

The moisture content of the timber at time of laying is very important.

Test the moisture content of at least 5 randomly selected boards with a moisture meter when the timber is delivered or insist the supplier provides readings. Readings from the meter must be corrected for species and temperature with correction factors available at: www.tastimber.tas.gov.au.

Unless otherwise agreed with the supplier, reject the material if corrected moisture content readings are over 14% or under 9%. This is outside the Australian Standard.

If necessary, allow the timber to acclimatise to long term service conditions.

Typically, timber supplied to the Standard should have a moisture content suitable for normal temperature and humidity conditions in most locations.

Where service conditions vary considerably from normal, such as in air-conditioned, centrally heated or hot sunny rooms, the timber should be acclimatised by racking it out in the room with strips between each row of boards. The timber should be left with the heating or air conditioning running, until the moisture content is satisfactory.

The more the expected service conditions in the room vary from normal, the longer the boards need to be acclimatised.

Timber	Service Environment	Response and Required Action
Flooring supplied at a moisture content between 10% and 12 %	Moist Conditions Average MC between 12.5–16% Cool & damp or hot & very humid	Timber expands <ul style="list-style-type: none"> • Provide extra expansion joints • Acclimatise
	Normal Conditions Average MC between 10–12.5%	Timber remains relatively stable.
	Dry Conditions Average MC between 8–10% Air conditioned, centrally heated, or with large northern windows	Timber contracts <ul style="list-style-type: none"> • Acclimatise • Consider alternatives to polyurethane finishes

STORAGE

Protect the timber from moisture during all stages of construction.

Avoid exposing the timber to rain, dew or direct sunlight. Keep it away from the ground or newly laid concrete. Repair damage to pack covers immediately.

Ideally, the flooring should be stored in a fully enclosed area where it is to be laid, or in a similar environment.

Handle the timber carefully

Protect the upper surfaces and the tongues of the boards from damage.

PREPARATION

Only install the flooring in a fully weatherproofed building.

The roof should be on, windows & external doors installed, exterior cladding finished and wet trades complete. The storm water system must be complete or effectively taking water away from the sub-floor or slab.

Do not lay the floor if there is any sign of water entering the work area.

Substrates must be dry.

Concrete

Concrete slab must be dry, with a moisture content no more than 5.5%. This can be measured with a hygrometer moisture test. An alternative method is to seal a 450 mm square sheet of plastic or glass to the slab. If the slab darkens or there is any condensation after a day, the slab is too wet to install the floor. It must be left to dry out or be sealed.

Whatever their age, all slabs should be regarded as a source of moisture. If in doubt or if there is evidence of previous water penetration:

- seal the slab with a proprietary waterproofing compound; or
- install a 0.2 mm plastic membrane under a plywood underlay. Lay the plastic over the whole of the floor, overlap the joints by 200 mm and tape them. Lay the plywood so that the sheets run 90° to the intended direction of the board and fix with 2.9 mm concrete nails. Space these 100 mm in from the edge and at 550 mm centres along the grain and 500 mm across the grain.

Do not lay the flooring directly on a damp slab.

Sheet flooring or boards

Sheet flooring or boards must be dry, with a moisture content no more than 14%. This can be measured with a resistance moisture meter.

The ground under sheet or board substrates should be dry and sub-floor ventilated to the requirements of the Building Code of Australia as a minimum. In renovation projects, clear existing ventilators or install additional ventilators in the perimeter walls.

Where conditions under the floor are damp & the potential for additional drainage or ventilators limited, install a continuous impervious plastic membrane over the ground and fixed up the perimeter walls. Lap and tape the joints. The space above this barrier must still be ventilated.

Substrates should be solid, level, true and provide a good key for gluing.

Surfaces should be flat & sound. Check the surface with an automatic level or a level and a straight edge. The variation from a 3 m straight edge should not exceed 3 mm. Level uneven surfaces with a levelling compound. Follow the manufacturer's recommendations exactly.

Concrete

If the surface of the concrete is crumbly or broken, install a plywood underlay as described above. If the surface is generally sound, patch any local surface damage.

Sheet flooring or boards

Skim sand existing boards or particleboard and plywood floors to provide a clean, flat gluing surface. Plug any holes and repair any damage to the surface. If the floor squeaks, force a bead of elastomeric glue into the joint between the top of the joists and the flooring.

Keep the site and work area clear and clean.

Clean and vacuum the substrate. Arrange the work area so that sawdust from cutting boards is excluded from where boards are laid. Put unneeded tools away.

SANDING & COATING

Prepare the floor thoroughly.

The quality of the finished timber floor depends heavily on the quality of the surface preparation. Ensure that all exposed nails are punched adequately. Fill any holes or gaps with a filler compatible with the floor finish.

Select the coating system to suit the project.

Moisture curing & 2 pack polyurethanes produce a clear, very hard-wearing surface in a matt, satin or high gloss finish. However, they darken with age. If applied to a poorly laid or unstable floor, they can also glue the tongue of one board into the groove of the next.

Water-based polyurethanes can produce a clear, hard-wearing surface in a matt, satin or gloss finish. While more expensive, they produce less fumes during application & curing, & are trafficable earlier. They can also glue boards in an unstable floor together.

Modified oil coatings are clear varnishes, generally made from a mixture of resin & oil. Easy to apply & penetrating, these give a slightly softer look than polyurethanes but are less hard wearing & darken with age. A surface polish is recommended to reduce maintenance in high traffic areas.

Oils are penetrating finishes that are generally less hard wearing than the modified oils or polyurethanes. They give a soft, natural appearance but require regular maintenance.

Employ professional sanding and finishing contractors.

The floor needs to be sanded to a flat & level surface. Deep scratch marks should not be present or accepted. Equally, do not expect a "furniture quality" finish on site.

FINISHING

Follow the finish manufacturer's instructions exactly.

Many problems with timber floors are due to inappropriate application of the finish. Do not thin the finish unnecessarily. Only apply polyurethane or two part coatings to tight, well-laid floors at the correct moisture content. These coatings can glue boards together, causing 'clumping', 'slabbing' or other problems later.

CARE

Fit protective pads to your furniture.

Timber floors are resilient but they can be scratched by moving furniture. Inspect the bottom of lounges, chairs and sideboards. Some older furniture has metal buttons on the base of legs. Remove these. Fit adhesive felt and other soft pads to all legs and supports that will sit on the floor. The hard plastic feet on some stools can dent the timber. If this occurs, fit softer rubber pads.

Minimise dust.

Dust on the floor can scratch the surface of the finish, especially in high traffic areas. Install coir mats at doors. Vacuum and sweep regularly.

Wipe off marks with a damp cloth.

Most marks can be removed without the use of abrasives or chemicals. Do not wet mop the floor as it can lead to problems with the timber.

Clean up spills quickly.

Occasional spills should not significantly influence the floor if they are wiped up immediately. Persistent leaks from sinks or dishwashers will cause problems. They should be fixed immediately.

Timber Research Unit, University of Tasmania
email: Timber@arch.utas.edu.au
phone: 03 6324 3135



timber
research
unit

for more information contact

<http://www.tastimber.tas.gov.au>

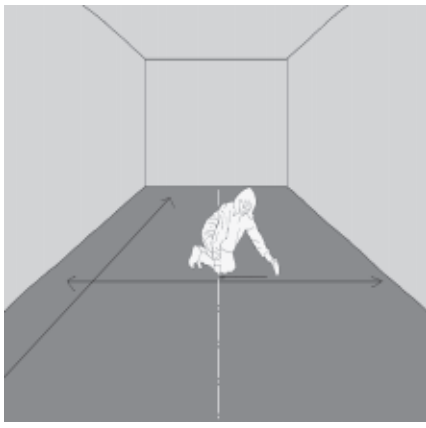

ONE

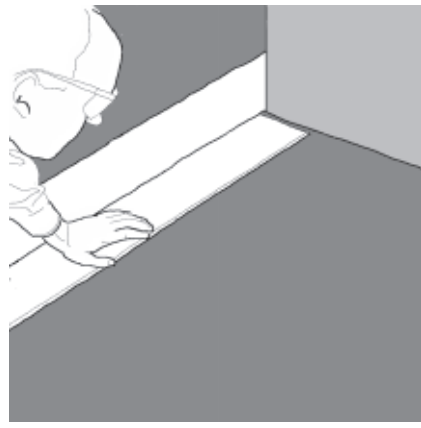

TWO

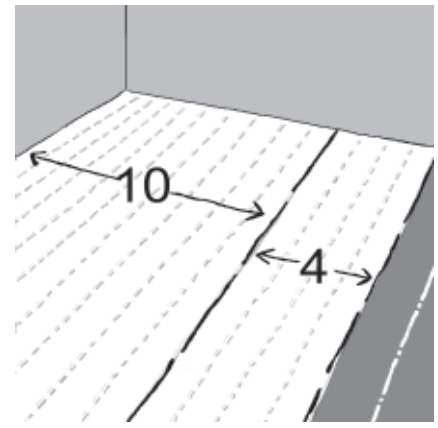

THREE

INSTALLATION

Plan and set out board direction.

Before you begin, clean up the site and work area.

Put unneeded tools away.

Use a string line, tape and square to check the exact shape of the room and if the sides of the room are parallel.

Decide on the exact line of the rows of boards to suit the room's shape.

Set this line out as a string line and mark it as the *reference line* near the centre of the room.

Take off existing skirting boards and trim door frames and architraves if necessary.

Concrete

The concrete should be clean, level and dry. If not, see the **preparation** section.

Sheet flooring or boards

Overlay boards should be laid at right angles to the board direction of existing board floors and at least 45° to the long edges of existing particleboard or plywood floors.

Plan intermediate expansion gaps in floors over 6 m wide.

A min. 10 mm gap is needed between the edge of the boards & any vertical barrier such as walls.

Floors over 6 m wide need intermediate expansion gaps at a rate of 10 mm per 6 m run across the boards.

These can be located at the threshold of a doorway or opening, or spaced evenly throughout the floor as a series of smaller gaps.

Use spacers about 2 mm thick between rows of boards about 1.2m apart to form these smaller expansion gaps.

Set out the position for the first row of boards.

Working from the reference line and the position of any planned expansion joints, set out another string line, the *board set out line*, that is:

- about 10 board widths away from one end wall, and
- EXACTLY parallel to the reference line in the middle of the room.

Then, set out another string line, a *gluing line*, towards the centre of the room 4–6 board widths away from and parallel to the *board set out line*.

Tip

Cut the boards in a separate work area. Keep dust or debris off the substrate and away from any glue.

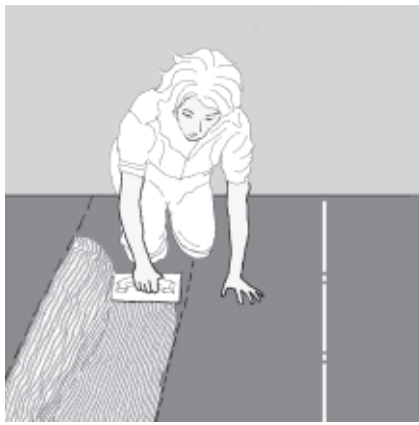

FOUR

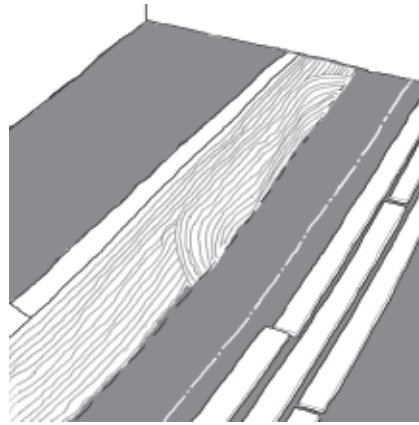

FIVE

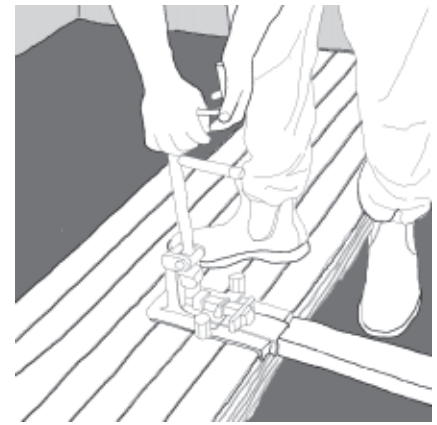

SIX

INSTALLATION

Use the full length and the machined ends of boards where possible.

Cut and arrange 4–6 full rows of boards ready for laying.

Sort the boards so that butt joints in adjacent rows are a minimum of 450 mm apart. Use shorter pieces at the ends of the rows.

Select boards to spread colour variation evenly through the floor.

Spread the glue at the recommended rate

Apply glue between the *board set out line* and the *gluing line*. Work up to the lines carefully starting at one end and then along the line to the other.

Make sure the *board set out line* is still visible

Lay the first board carefully.

Select long straight boards for the first row.

Position the first row of boards approximately in place along the *board set out line* with the groove to the line.

Starting from one end of the row, position the end of the first board exactly on the *board set out line* and fix.

On concrete, fix the first row with concrete nails.

On sheet flooring or boards, fix with nails into the substrate.

Move to the other end of the same board and position it exactly on the *board set out line*. Fix it into place.

Repeat this at the centre of the same board.

Continue with next board in the row until the first row is complete and solidly fixed in place. Ensure any butt joints are tight.

This board needs to be fixed securely so that it will not move when later boards are cramped up to it.

Position boards carefully in the glued area and nail.

Lay boards in place against this initial row until all the rows in the glued area between the *board set out line* and the *gluing line* are laid.

Position boards carefully as near as possible to their final position so the glue is not squeezed up between the boards as they are moved into place. Push or tap them into place with a timber block or off cut.

Ensure all end joints are tightly closed and distributed evenly throughout the floor. Push them in from the end if necessary.

If the boards do not close up tight, check for debris between the boards.

Close any gaps in the boards, cramping the boards off a wall if possible.

Fix the last row of boards in the panel with nails, leaving concrete nails protruding so they can be easily removed later.

If secret nailing, cramp and fix each board tightly as it is laid.



SEVEN

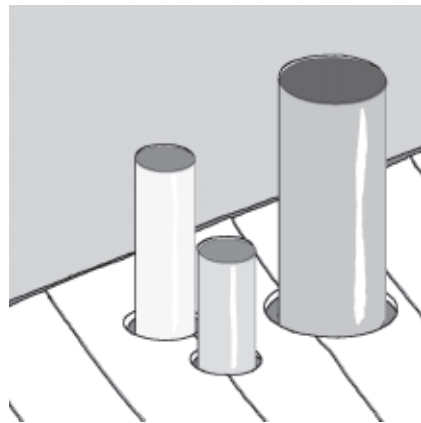

EIGHT



NINE

INSTALLATION

Use the correct number and length of fasteners.

Australian Standard 1684 establishes minimum fastener dimensions for fixing flooring without glue. These are set out in the **Materials** section above.

In nail only applications, boards over 85 mm cover wide should be surface nailed with two nails per joist.

Tip

Use no more than three concrete nails in one small area. If the nails won't hold a board down, then use a weight until the glue has cured.

Cut around any pipes or penetrations.

Mark the boards carefully and cut them with a hole or jig saw. Boards should finish 10 mm clear of the penetration or pipe.

Tip

When gluing a timber floor, do not work with any more than 4–6 rows of boards at a time as the glue can skim over and its effectiveness is reduced. Any glue protruding from an area that will not be worked with for some time should be removed.

Repeat the process until the floor is almost complete.

Work off the laid boards with about 4–6 rows at a time.

Mark a gluing line from the edge of the laid boards each time, apply the glue at the required rates up to it, then lay and fix the boards.

Incorporate intermediate expansion gaps if they are required.

Work until the floor is laid to about two boards away from each wall.

Concrete

Restrain the rows with enough removable concrete nails to hold the boards tight.

Sheet flooring or boards

Continue to secret nail or surface nail as you lay the rows.

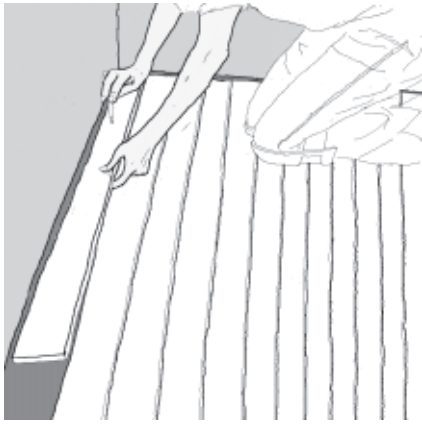

TEN

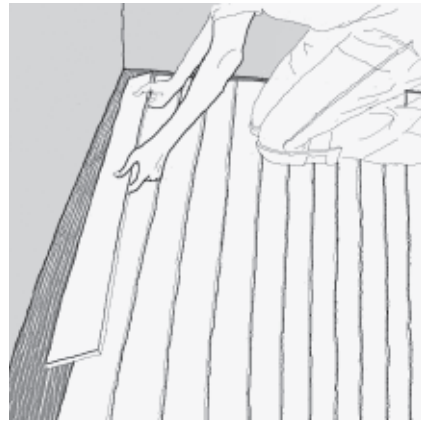

ELEVEN



TWELVE

INSTALLATION

Set out the last boards carefully.

Select long straight boards for the last rows.

Without applying any glue, position the last row of boards approximately in place.

Make sure the flooring clears any obstructions.

Generally, the last row of boards will have to be cut along their length to complete the floor.

Remember that a minimum 10 mm gap is needed between the edge of the boards and any vertical barrier such as a wall.

Using a ruler or tape, scribe the line of the wall onto the last boards so that when cut, it will fit in the remaining space.

Remove the last boards and cut to the line.

Position them against the wall and check that the final boards fit neatly, clearing any obstructions.

Remove the final boards and any dust or debris on the substrate.

Install the last boards carefully.

Apply glue at the recommended rate in the remaining area neatly.

Position all but the last row of boards carefully in the glue, and work into place.

Finally position the last row of boards, cut to fit to the wall.

Close any gaps between the boards. Pack the boards off the wall if necessary and fix.

Leave glued floors for the required curing time.

Manufacturers recommend different curing times. Follow their instructions.

Once the glue has cured, exposed nails can be removed or punched below the surface.

Protect the boards prior to sanding and finishing.

Plaster board setting compounds can stain timber and silicone sealants and glues can affect the bond of the finish. Scaffolding, ladders and dropped tools can dent timber significantly.

Cover the completed floor with cardboard, plastic and drop sheets.